

PF8910L

VESPUCCI WASH COMBI OVEN 10 TRAYS 600X400 - GN 1/1 LATERAL DOOR

PIRON
your professional cooking

rev: PF8910L_PI1



Load Capacity		n°10 - EN 600x400 - GN 1/1
Space between trays		80 mm
Cooking chamber dimensions - Gross volume		66x44x93 cm - 270 lit
WxDxH - Width x Depth x Height		78x85x120 cm
Nominal power	kW	15.8 kW
Heating power		3x5000W @ 230V
Motor power		3x250W @ 230V
N° motor speed phases		3
Reverse		Reverse air flow
Nominal voltage		400V 3N~
Nominal Current		22/22/25/4 A
Suggested cross section cable		5x4 mm ²
Frequency		50/60 Hz
N° cooking programs		99
Cooking chamber material	AISI	Inox AISI304
Timer		0 - 10h
Core probe		1x optional
Automatic washing system		•
Humidity/Steaming		Sator steam
Temperature		30 - 270 °C
Pre-heating		+30 °C
Rapid steam evacuation		Optimal climatic
Waterproof level		IPx4
Net weight		121 kg
WxDxHi - Width x Depth x Height - Package		85x103x136 cm



PF8910L

VESPUCCI WASH COMBI OVEN 10 TRAYS 600X400 - GN 1/1 LATERAL DOOR

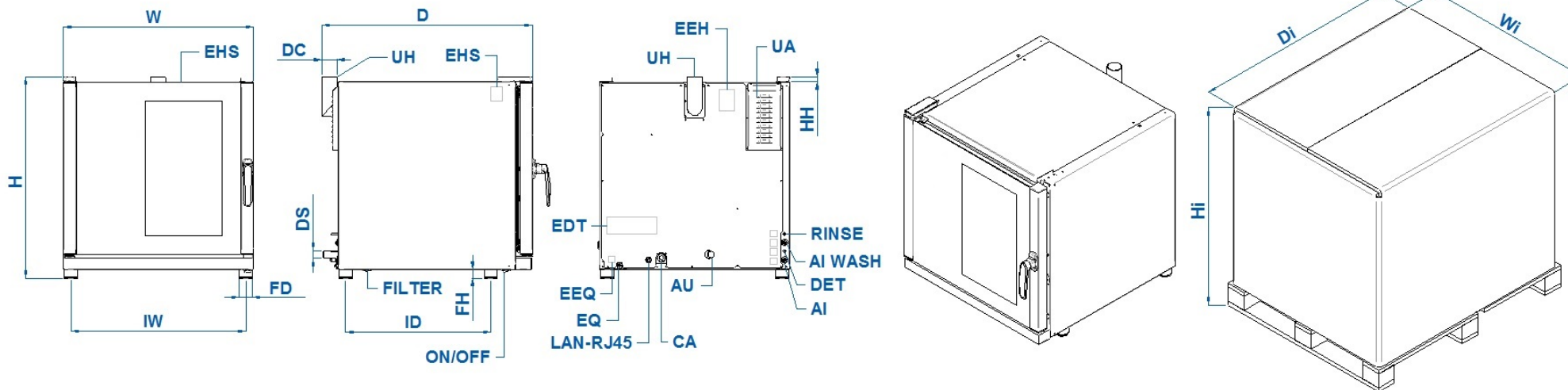

UH - Exhaust hot fumes

UA - Cooling air exit

CA - Power Cord

EQ - Equipotential terminal

EHS - Hot surface label

EDT - Datasheet label

AI - Water in

AU - Water out

EAI - Water in label

UC - Non-return valve

RF - Junction Ø8 - 3/4

RG - Junction Ø8 - Ø8 90°

EEQ - Equipotential label

EHH - Exhaust hot fumes label

IW : 70 cm

ID : 58 cm

FD : Ø 5,2 cm

FH : 5.5 cm

DC : Ø 6 cm

HH : 2 cm

DS : Ø 3 cm

Wheelbase feet - width

Wheelbase feet - deep

Ø feet

Feet height

Ø exhaust pipe

Hinge height

Ø water out pipe

PF8910L

VESPUCCI WASH COMBI OVEN 10 TRAYS 600X400 - GN 1/1 LATERAL DOOR

